



# The **SWAM-Blaster**<sup>®</sup> *Environmentally Friendly* Automated Conformal Coating Removal System Model CCR-NP16X16

## The Model CCR-NP16X16 Conformal Coating Removal Nozzle Positioning System

The Nozzle Positioning Work Cell is built upon the Complete Work Cell concept requiring only a single power and single air drop. The system is computer controlled with a touch screen user interface. User enters the area to be blasted (up to 16"x16"), number of passes and from which side to make the passes. The nozzle is mounted at 60 degrees in relation to the board. The board is placed on a rotary table rotating in 90 degree increments to insure full board coverage. The system can be used in either "Sandblast Automatic" mode or "Sandblast Manual" mode for doing touch up manually. Nozzle Positioning Work Cell includes the following:

- Roomy work chamber with ionization bars
- Nozzle Ionization points for Manual or Auto mode
- Brightly lit with dual white and UV fluorescent bulbs
- Tempered glass viewing window
- Oval angled arm holes for operator comfort
- Microscope Mount Pivot Assembly
- Rugged powder coat finish
- Swing platform for **SWAM-Blaster**<sup>®</sup> Model LV-1
- Lockable swivel castors/leveling feet
- Built in Dust Collector
- Built in Air Dryer
- Touch Screen Operation & programming
- Stores 99 programs

### Removes

- **Parylene**
- **Silicones**
- **Urethanes**
- **Epoxies**
- **Acrylics**



**ENVIRONMENTALLY FRIENDLY  
NO SOLVENTS!**



*Optional: ESD Field Meter for testing system*

Represented by:

**CRYSTAL MARK, INC.**

A SWAN TECHNOLOGIES CORPORATION

613 Justin Avenue Glendale, California 91201-2396

(818)240-7520 • (800)659-7926 • FAX (818)247-3574

www.crystalmarkinc.com • sales@crystalmarkinc.com



# Environmentally Friendly Conformal Coating Removal

## No Solvents!

### CRYSTAL MARK, INC.

manufactures manual and automated micro sandblast systems for selectively removing most types of conformal coatings from various components including printed circuit boards without causing mechanical or ESD damage.

The top of the line **SWAM-Blast® Model CCR-NP16X16** system was specifically designed for selectively removing conformal coatings from pinpoint areas to an entire surface up to 16" x 16".

As with all **CRYSTAL MARK, INC.** micro sandblasters it features independently adjustable powder flow control and air pressure regulation, easy access to the abrasive pathway for maintenance as well as large carbide lined components throughout the abrasive pathway for extended wear life and optimum powder volume.

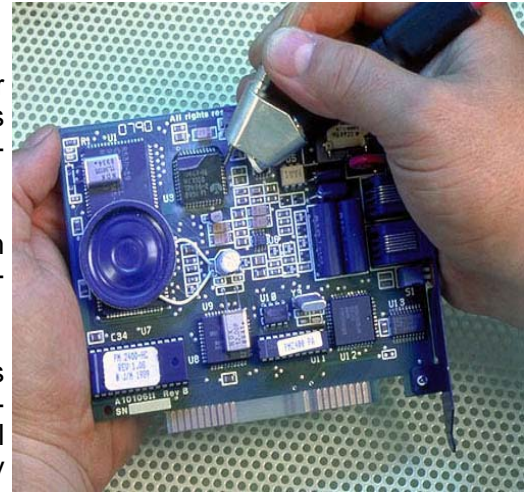

When conformal coated components are sensitive to Electro-Static Discharge (ESD), the **Point Ionizer™** effectively reduces the ESD from reaching levels that could potentially cause damage to the component during the removal process.

**CRYSTAL MARK, INC.** offers several types of abrasive powders available for conformal coating removal including **Environmentally Friendly Carbo Blast™** and **Soda Bicarbonate**. **Environmentally Friendly Carbo Blast™** successfully removes most types of conformal coatings including **Parylene, Silicones, Urethanes, Epoxies, Acrylics** and their blends. **Environmentally Friendly Carbo Blast™** is great for PCBs as it does not cause mechanical damage to the butter coat of the board when used properly. Soda Bicarbonate is more aggressive than Carbo Blast and both are water soluble. Plastic Blast is another abrasive powder, as it is harder than Soda Bicarbonate and can remove many conformal coatings.

**CRYSTAL MARK, INC.** can design and build custom work chambers and components to meet your special requirements.

We offer an Electro Static Field Meter for periodic ESD metering and microscopes as accessories.

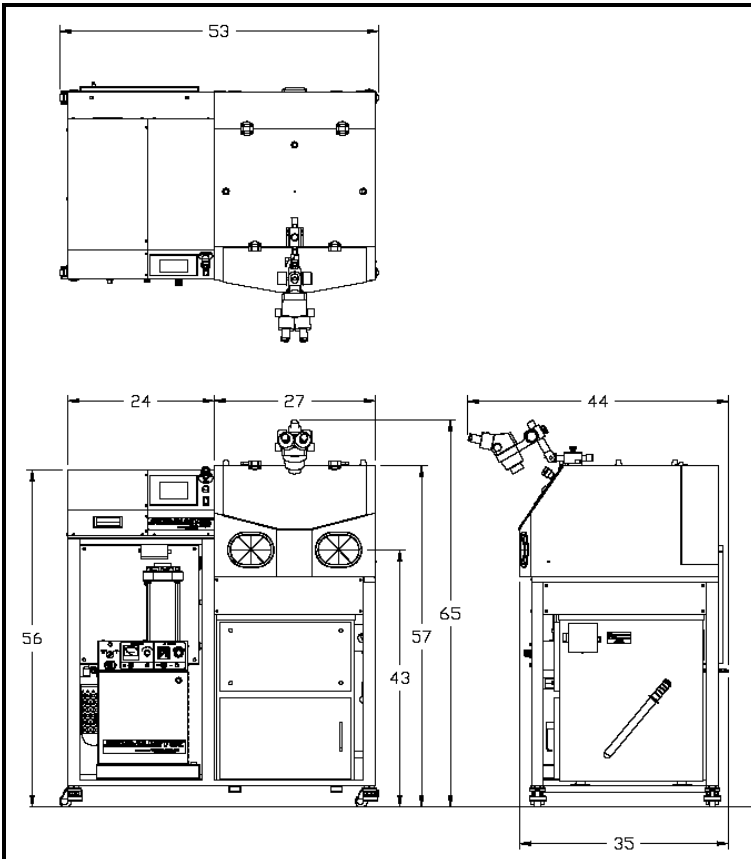

### Specifications:

Model / Part Number:	CCR-NP16X16
Power:	115V/60Hz, 1 phase, 15 amps
Air Requirement:	5 SCFM at 140 psi max, 40 psi min
Size:	53" L x 35" D x 56" H
Weight	550 pounds
Chamber Interior:	24" wide, 17" high x 19" deep
Window:	Tempered Glass
Dust Collector Motor:	1 horsepower blower
Air Flow:	400 cfm
Filter:	55 sq. ft. cotton sateen
Silencer:	Built into cabinet, 67db sound level

Other Power: 100V/50Hz , 110V/60Hz, 230V/50Hz & 230V/60Hz